

# Fortra™



## 2Gb/s Fibre JBOD 6-bay Desktop Enclosure

### Installation Guide

July 12, 2002 • Revision A

Patent Pending

# JMR

# JMR



### Copyright

Copyright ©1998, 1999, 2001 by JMR Electronics, Inc. All Rights Reserved. No part of this publication may be reproduced, transmitted, transcribed, stored in a retrieval system, or translated into any language, in any form or by any means, electronic, mechanical, photocopying, recording or otherwise, without the express written permission of JMR Electronics, Inc.

### Sales and Ordering Information

JMR Electronics, Inc.  
20400 Plummer Street  
Chatsworth, CA 91311 USA  
Phone: 818-993-4801  
Fax: 818-993-9173  
Office Hours: Monday-Friday 8:00 A.M. to 5:00 P.M., Pacific Standard Time

### European Corporate Headquarters

JMR Electronics United Kingdom  
Iain Pickthall  
P.O. Box 3058 Wokingham  
Berkshire - RG40 3FU - United Kingdom  
Phone: + 44-118-973-6018  
Fax: + 44-118-973-7191  
E-Mail: iain@jmr.com

Internet: <http://www.jmr.com>

### Trademarks

JMR, the JMR logo, and **FORTRA**® are registered trademarks of JMR Electronics, Inc. All other product and brand names are the property of their respective holders.

### Changes

The material in this document is for information only and is subject to change without notice. JMR Electronics, Inc. reserves the right to make changes to this manual and the equipment described herein without notice. JMR has made all reasonable efforts to ensure that the information in this manual is accurate and complete. However, JMR shall not be liable for any technical or editorial errors or omissions made herein or for incidental, special, or consequential damage of whatsoever nature resulting from the furnishing of this manual, or operation and performance of equipment with this manual.

### Disclaimer

The original product packaging has been tested and is safe under normal shipping circumstances. Reshipping the product without using the original product packaging will void the warranty. Do not ship the unit with canisters or power supplies installed as this will void the warranty and could cause damage to the unit and drives. The canisters should be packaged separately within the product packaging as provided.

### FCC Information

The **FORTRA**® equipment generates, uses and can radiate radio frequency energy. If the **FORTRA**® Array is not installed and used properly (that is, in strict compliance with these instructions), it may cause interference to radio and television reception.

The **FORTRA**® equipment and its contents are designed to comply with the limits for a Class A computing device in accordance with the specifications in Part 15 of FCC rules. These rules are designed to provide reasonable protection against radio interference in a commercial installation. However, there is no guarantee that interference will not occur in a particular installation. Operation of this equipment in a residential area is likely to cause interference, in which case the user, at his own expense, will be required to take whatever measures are necessary to correct the interference.

**WARNING:** Changes or modifications, not expressly approved by the manufacturer, could void the user's authority to use the equipment.

**WARNUNG:** Nicht ausdrücklich durch den Hersteller genehmigte Änderungen oder Modifikationen können die Erlaubnis Zur benutzung der Produkte gefährden.

You may find the FCC booklet, How to Identify and Resolve Radio Interference Problems, helpful. This booklet is available from the U.S. Government Printing Office, Washington, DC 20402. Stock #004-000-00345-4.

Printed in the USA  
Part Number PUB-00278  
Revision A, July, 2002 SCS  
Patent Pending



## Table of Contents

### 1. Introduction

2/4/6/8/10/12/15-bay Product Family Features .....	1-1
6-bay Desktop Specifications .....	1-2
Fibre Channel Features .....	1-2
Loop Expansion .....	1-2
Dual Loops (A & B) .....	1-2
ID Selection .....	1-2

### 2. Hardware Specification

Environmental Specifications .....	2-2
Electrical Specifications .....	2-2
Agency Compliance .....	2-2
Packaging Specifications .....	2-2
Disclaimer .....	2-2
Thermal Specifications .....	2-3
Rotation Vibration Specifications .....	2-3
Fault Indication Features .....	2-3
Fault Indicators .....	2-3
Audible Alert .....	2-3

### 3. Device Installation

SCA Connection and Hot-Swapping .....	3-1
Locking/Unlocking .....	3-1
Canister Removal/Insertion .....	3-1
Drive Installation .....	3-2

## Handle

### 4. Fibre Channel Setup

Default Slot ID .....	4-2
Setting Slot ID .....	4-2
Option Settings .....	4-4
Fibre Channel Speed Selection (W5) .....	4-4
Rear I/O Connections .....	4-5
CH-A 1 .....	4-5
CH-A 2 .....	4-5
CH-B 1 .....	4-6
CH-B 2 .....	4-6
System Fault Audible Alert .....	4-6





Alarm Reset .....	4-6
<b>5. Blower Operation</b>	
Blower Removal/Insertion .....	5-1
Blower Replacement .....	5-2
<b>6. Power Supply Operation</b>	
Power Supply Removal/Insertion .....	6-1
Power Supply Replacement .....	6-2
<b>7. Product Support</b>	
US Corporate Headquarters .....	7-1
Manual Changes .....	7-1
<b>Appendix A. Drive and Controller Manufacturers</b>	
Drive Manufacturers .....	A-1
RAID Controller Manufacturers .....	A-1
Host Bus Adapter Manufacturers .....	A-2



# 1. Introduction

The 6-bay **FORTRA**® 2Gb/s Fibre JBOD enclosure is designed for use with a host system to provide a high-end storage solution. The following is a summary of the 6-bay enclosure features:

- The 6-bay **FORTRA**® 2G Fibre JBOD Desktop enclosure is a six drive enclosure that supports up to six 3.5" LP (Low-Profile) SCA (40-pin) drives. The Fibre Channel uses SFP transceiver connections and supports dual ports (A & B) and additional connections on each port for loop expansion.

## 2/4/6/8/10/12/15-bay Product Family Features

**FORTRA**® and **StorBlade**™ are families of high-end enclosures designed for high-volume performance storage solutions. The following table shows the features of the **FORTRA**® 2/4/6/8/10/12/15-bay and **StorBlade**™ products:

	2-bay	4-bay <sup>1,3</sup>	6-bay <sup>1,3</sup>	8-bay <sup>1</sup>	10-bay <sup>1,2</sup>	12-bay	15-bay <sup>1,3</sup>	StorBlade
Number of Device Bays	2	4	6	8	10	12	15	4
Number of Blowers	1	1	1 or 2	2	2	2	2	2
Number of Power Supplies	1	1	1 or 2	2	2	2	2	1 or 2
Number of I/O Channels (SCSI Only)	1	1	2	2	2		2	2
SCSI SE/LVD Supported	✓	✓	✓	✓	✓		✓	✓
Fibre Channel Supported		✓	✓	✓	✓		✓	✓
Hot-Swap Canisters	✓	✓	✓	✓	✓	✓	✓	✓
Removable Power Supplies	✓	✓	✓	✓	✓	✓	✓	Fibre only
Removable Blowers	✓	✓	✓	✓	✓	✓	✓	Fibre Only
N+1 Power Supplies			✓	✓	✓	✓	✓	Fibre only
N+1 Blowers			✓	✓	✓	✓	✓	✓
MIA Support (FC Only)		✓	✓	✓	✓			
Loop Expansion Support (FC Only)		✓	✓	✓	✓		✓	✓
Daisy Chainable (SCSI Only)	✓	✓	✓	✓	✓			✓
Built-in Termination (SCSI Only)			✓	✓	✓		✓	
Auto Termination (SCSI Only)			✓	✓	✓		✓	
SAF-TE/SES Ready (Optional)			✓	✓	✓		✓	Fibre only
SAF-TE/SES Compatible			✓	✓	✓		✓	Fibre only
SCSI to SCSI RAID Support				✓	✓		✓	✓
Fibre to SCSI RAID Support					✓		✓	
Fibre to Fibre RAID Support					✓		✓	✓
Fibre to ATA RAID Support						✓		
SCSI to ATA RAID Support						✓		
(D)esktop/(T)ower/(R)ackmount	D	D	DTR	T	TR	R	TR	R

\* 6/10/15-bay unit features apply to both Tower and Rackmount models  
<sup>1</sup> Features are based on a standard configuration with no internal host controller(s) installed  
<sup>2</sup> Fibre channel 10/15-bay enclosures have built-in SES  
<sup>3</sup> Fibre Channel 2Gb Model available. 2Gb models use SFP transceivers.





**FORTRA**<sup>®</sup> products use advanced mid-plane technology developed by JMR, that allows power supplies, drives, and all other enclosure components to interface into a single board. This provides superior performance and easy connectivity.

The host interface supports Fibre Channel interfaces as long as the drives have SCA connectors. Connection to a Fibre Channel host or expansion enclosure are made using a SFP transceiver connectors.

## 6-bay Desktop Specifications

### Dimensions/Weight

Unit Weight	19.7 lbs. (9.0kg)
Height	11-1/2" (292mm)
Width	7-3/4" (197mm)
Depth	12-1/2" (316mm)

### Power Supply

Quantity:	1
Power:	300 Watts
Input:	115-230 VAC; 50-60Hz (auto-switching)
Output:	+5V @ 20A +12V @ 17A

### Blower

Quantity:	1
Size:	125mm (4.92") each
Air Flow:	27.2CFM (0.76m <sup>3</sup> /min)
Noise:	51dB(A)

## Fibre Channel Features

### Loop Expansion

**FORTRA**<sup>®</sup> Fibre Channel enclosures include a loop expansion I/O connector on each port. This allows the connection to other Fibre Channel enclosures, switches, servers, hubs, and other Fibre devices.

### Dual Loops (A & B)

A single loop is required for unit operation however both loops can be used to connect to different hosts, dual host adapters, and other devices, for flexible and even redundant configurations. For specific connection and installation information, refer to [Chapter 4](#).

### ID Selection

0-127 device ID addresses are addressable and can be easily set-up via ID jumpers for each slot. For specific connection and installation information, refer to [Chapter 4](#).



# 2. Hardware Specification

This chapter covers specification information for the 6-bay **FORTRA**® enclosures. The following matrix describes the identification codes for the available configurations for all **FORTRA**® and **StorBlade**™ enclosures.

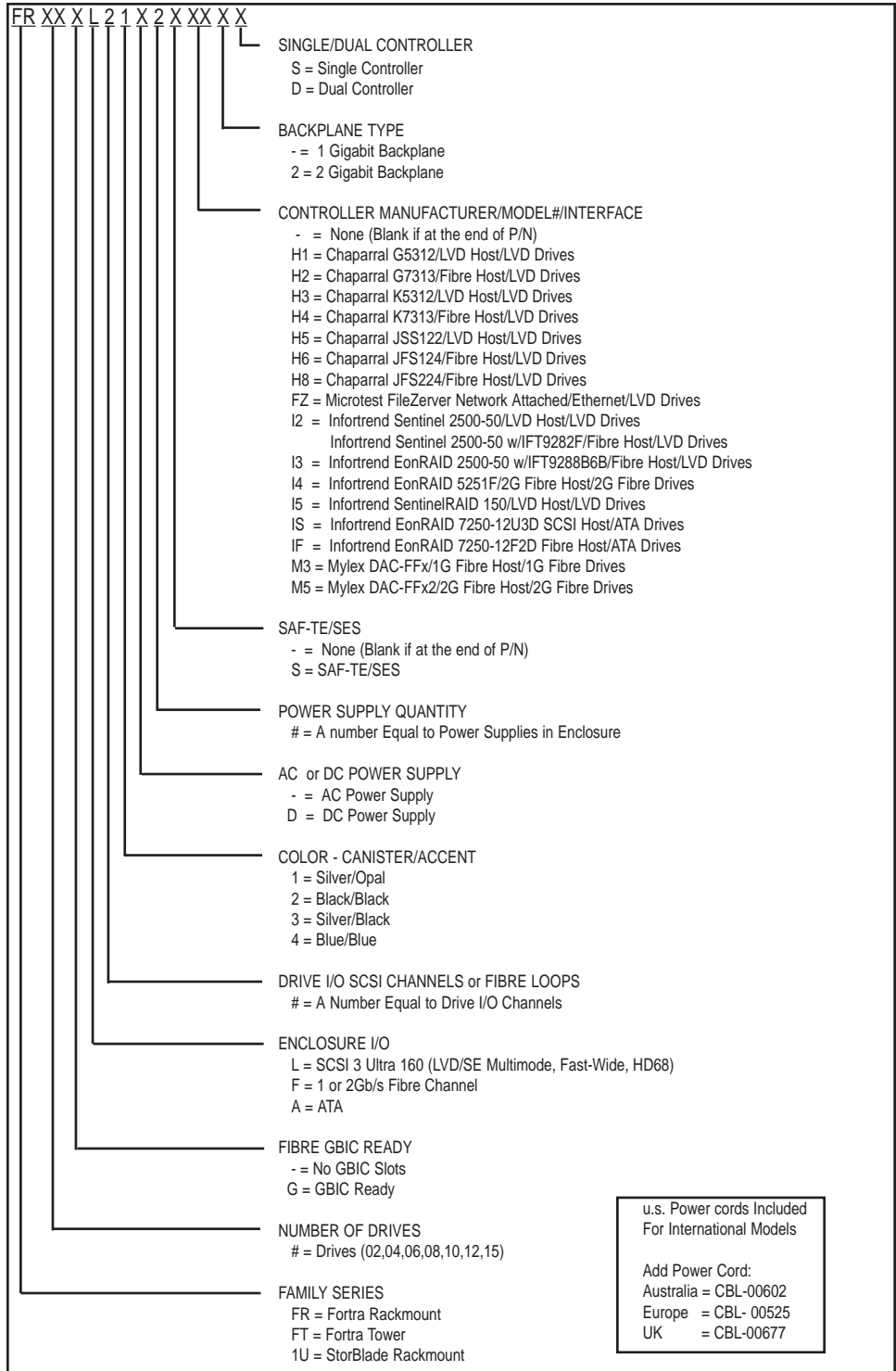



## Environmental Specifications

**Operating Temperature:** 5°C to 40°C (41°F to 104°F)

**Storage Temperature:** 0°C to 65°C (32°F to 149°F)

Maximum ambient temperature is dependent on the recommended temperature to meet the MTBF rating as specified by the manufacturer of the installed devices.

## Electrical Specifications

**AC Inlet Type:** IEC320/EN60320

**Power Cord:** NEMA5-15P

**Power Supply:** Auto-switching for 110/220V operation

## Agency Compliance

**FORTRA®** enclosures have been designed and built to comply with the FCC Class A, UL, CSA/TUV, CE, and C-Tick standards. For more information on FCC Class A compliance, see page 2.

## Packaging Specifications

**FORTRA®** packaging has been designed to be reusable and recyclable. Drives may be installed and shipped in the canisters as long as the canisters are in their original packaging location and are not installed in the enclosure. Shipping the unit with canisters and/or power supplies installed in the enclosure may cause damage to the enclosure or to the drives and will void the warranty.

**SAFETY TIP:** *Reshipping the enclosure with canisters, drives, or power supplies installed in the enclosure may cause damage to these components and will void the warranty*

**SICHERHEITSHINWEIS:** *Der Versand des Gehäuses mit eingebauten Einschüben, Platten und Netzteilen kann zur Beschädigung dieser Komponenten führen und somit den Garantieanspruch gefährden.*

Packaging complies with ISTA (International Safe Transit Association) standards and has been ISTA certified.

Each canister is pre-packaged in an anti-static bag. Do not throw the packaging away if the product is intended for re-shipping. When transporting or shipping a JMR approved shipping container must be used.

### **Disclaimer**

The original product packaging has been tested and is safe under normal shipping circumstances. Reshipping the product without using the original product packaging will void the warranty. Do not ship the unit with canisters and/or power supplies installed in the enclosure as this will void the warranty and could cause damage to the unit and drives. The canisters should be packaged separately within the product packaging, as provided.





## **Thermal Specifications**

**FORTRA**® enclosures have been designed to meet the air-flow/cooling requirements for popular 7,200, 10,000 and 15,000 RPM disk drives. Using a high performance blower, air is pulled in from all open vents and exhausted out the back of the unit.

## **Rotation Vibration Specifications**

**FORTRA**® enclosures have been designed to meet the rotation vibration/shock requirements for popular 7,200, 10,000 and 15,000 RPM disk drives.

## **Fault Indication Features**

This section reviews the indicators that will notify the user of a power supply or blower that is in a fault state. More information is available in [Chapter 5](#) (blowers) and [Chapter 6](#) (power supply).

### ***Fault Indicators***

All slots will blink 'Red' in color on a blower fault. On a power supply fault, the front power supply LED will blink on and off.

### ***Audible Alert***

On a blower or power supply fault, an audible alert will sound. Pressing the Alert Reset button on the back of the unit will turn the alert off.



## 3. Device Installation

This chapter covers Fibre Channel device installation for 6-bay desktop enclosures.

### SCA Connection and Hot-Swapping

The unit uses SCA-2 type connectors which provide a safe means of connection/disconnection when hot-swapping devices. In order to utilize this feature, the host adapter or RAID controller and host operating software must support the feature. Any SCA drive is capable of plugging directly into the backplane of the unit and should not require any additional cabling or connections.

### Locking/Unlocking

A front lock prevents unwanted removal of the canisters including the power supply canister. Before attempting to remove any drive or the power supply, insure that the enclosure is in the Unlocked position.

### Canister Removal/Insertion

1. The photo to the right shows the canister in a locked position.

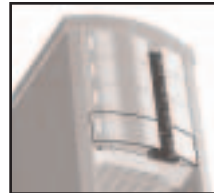

2. Pull the handle out to unlock the canister from the **FORTRA**® unit. Ensure that the thumb is placed below the line. Pressing the thumb against the Status LED lens could break it. Notice that the locking tab slides down as the handle is pulled out.



**SAFETY TIP:** After disengaging a device from the enclosure, allow 10 seconds before pulling the canister out of the unit. This allows the device to properly spin/shut down before transport.

**SICHERHEITSHINWEIS:** Nachdem ein Einschub vom Gehäuse wie in "Step 3" gezeigt gelöst wurde, warten Sie bitte ca. 10 Sekunden bevor der Einschub ganz heraus gezogen wird. Dies ermöglicht den Auslauf der Festplatte bis zum vollständigen Stillstand der rotierenden Scheiben für einen sicheren Transport.

3. Pull the canister straight out to remove. Ensure that any installed devices are spun down before full removal to prevent damage to the drive.



Follow the steps in reverse to reinstall.

## Drive Installation

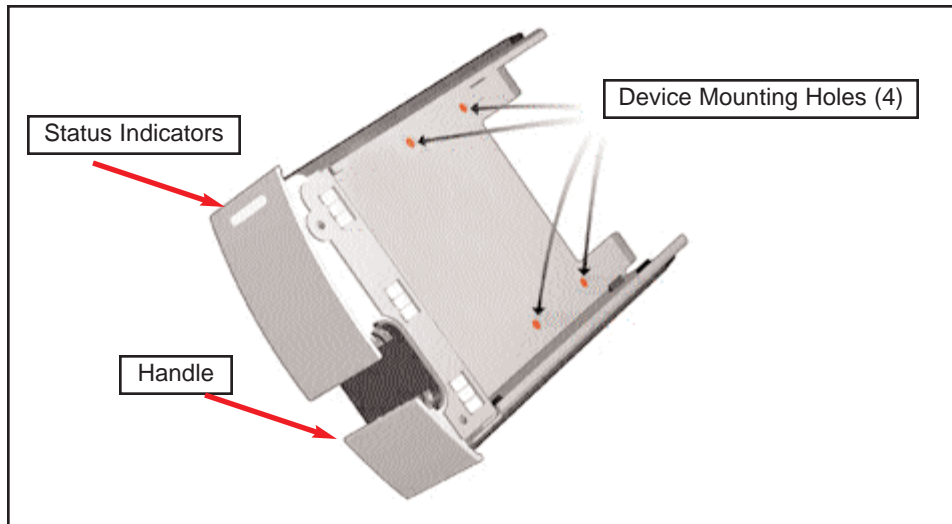

Device mounting screws are included with the unit for device mounting. The JMR part number for the #6-32" mounting screws is HDS-01906.

**WARNING:** Before device installation, alleviate any electro-static discharge by touching a grounded metal assembly. Static can be potentially damaging to enclosure components.

**WARNUNG:** Berühren Sie vor der Festplatteninstallation geerdete Metallgegenstände, um elektro statische Aufladung abzuleiten. Statische Aufladung kann elektronische Gehäusekomponenten schwer beschädigen.

**WARNING:** The #6-32 mounting screws that are provided have been specially designed to fit the canisters. Do not install the device using any other screws than the ones provided.

**WARNUNG:** Die mitgelieferten Befestigungsschrauben #6-32 wurden speziell für die Einschübe angefertigt und zur Befestigung der Festplatte sollten Sie keinesfalls andere als diese verwenden.

1. After removing the canister, place it on a static free surface along with the device to be installed.
2. Place the device in the canister and mount it using the provided screws (use 4 screws to mount the drive).
3. Replace the canister into the unit by following the steps for Removal of a Device Canister but in reverse order.



4. Repeat steps 1 through 3 until all devices are installed.
5. Configure ID, and other options as required (see [Chapter 4](#)).
6. Establish host connection (see [Chapter 4](#)).



## 4. Fibre Channel Setup

This chapter covers the Fibre Channel setup.

**WARNING:** Take care when connecting the unit to an AC power source to ensure that it is plugged-in to a circuit of the appropriate rating (110v or 220v). For safe operation, the circuit should have over-current protection to prevent damage to the unit in the event of circuit overloading.

**WARNUNG:** Vergewissern Sie sich, daß die Netzspannung (220V / 110V) korrekt eingestellt ist, bevor Sie das Gerät mit dem Stromnetz verbinden. Zur Sicherheit sollte das Netz über einen Überspannungsschutz zur Vermeidung von Schäden im Falle einer Überlast verfügen.

**WARNING:** When connecting the unit to an AC outlet or power strip, ensure that the outlet has the proper connection for grounding. The AC power cables included with the unit have three prongs, one of which is used for the ground connection. Do not use a two prong AC cable with the unit since this will not allow for proper unit grounding and could cause problems with normal unit operation.

**WARNUNG:** Bei der Verbindung der Unit mit einer Steckdose oder einer Verteilerdose sollten sie auf eine korrekte Erdung derselben achten. Die mitgelieferten Kaltgeräteanschlußkabel habe 3 Kontakte, von denen einer zur Erdung verwendet wird. Verwenden Sie kein Stromkabel mit 2 Anschlüssen, da dieses keine korrekte Erdung ermöglicht und Probleme während des regulären Betriebs verursachen kann.

This figure shows the slot numbering sequence used to refer to device canisters and also shows the default ID value for each slot.

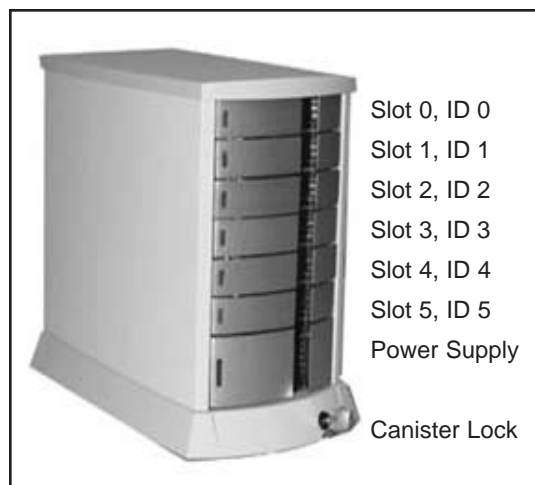

## Default Slot ID

Drive Bay	Default ID/Jumper
Slot 0 (top)	ID 0 / W1
Slot 1	ID 1 / W2
Slot 2	ID 2 / W3
Slot 3	ID 3 / W4
Slot 4	ID 4 / W6
Slot 5 (bottom)	ID 5 / W7

## Setting Slot ID

The ID for each slot can be set using jumpers located on the backplane of the unit. To access the jumpers the blower must be removed. To remove the blower refer to [Chapter 5](#).

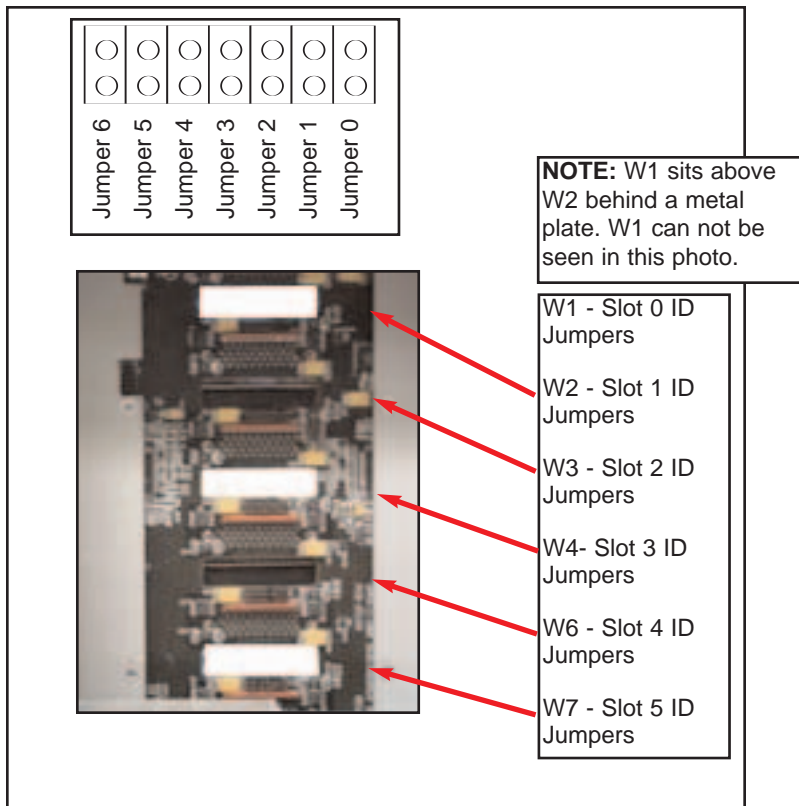

The following tables show the Fibre ID's and jumper settings for IDs 0-127.

Fibre ID	Jmp 0	Jmp 1	Jmp 2	Jmp 3	Jmp 4	Jmp 5	Jmp 6
0	C	C	C	C	C	C	C
1	O	C	C	C	C	C	C
2	C	O	C	C	C	C	C
3	O	O	C	C	C	C	C
4	C	C	O	C	C	C	C
5	O	C	O	C	C	C	C
6	C	O	O	C	C	C	C
7	O	O	O	C	C	C	C
8	C	C	C	O	C	C	C
9	O	C	C	O	C	C	C
10	C	O	C	O	C	C	C
11	O	O	C	O	C	C	C
12	C	C	O	O	C	C	C
13	O	C	O	O	C	C	C
14	C	O	O	O	C	C	C
15	O	O	O	O	C	C	C
16	C	C	C	C	O	C	C
17	O	C	C	C	O	C	C
18	C	O	C	C	O	C	C
19	O	O	C	C	O	C	C
20	C	C	O	C	O	C	C
21	O	C	O	C	O	C	C
22	C	O	O	C	O	C	C
23	O	O	O	C	O	C	C
24	C	C	C	O	O	C	C
25	O	C	C	O	O	C	C
26	C	O	C	O	O	C	C
27	O	O	C	O	O	C	C
28	C	C	O	O	O	C	C
29	O	C	O	O	O	C	C
30	C	O	O	O	O	C	C
31	O	O	O	O	O	C	C
32	C	C	C	C	C	O	C
33	O	C	C	C	C	O	C
34	C	O	C	C	C	O	C
35	O	O	C	C	C	O	C
36	C	C	O	C	C	O	C
37	O	C	O	C	C	O	C
38	C	O	O	C	C	O	C
39	O	O	O	C	C	O	C
40	C	C	C	O	C	O	C
41	O	C	C	O	C	O	C
42	C	O	C	O	C	O	C
43	O	O	C	O	C	O	C
44	C	C	O	O	C	O	C
45	O	C	O	O	C	O	C
46	C	O	O	O	C	O	C
47	O	O	O	O	C	O	C
48	C	C	C	C	O	O	C
49	O	C	C	C	O	O	C

Fibre ID	Jmp 0	Jmp 1	Jmp 2	Jmp 3	Jmp 4	Jmp 5	Jmp 6
50	C	O	C	C	O	O	C
51	O	O	C	C	O	O	C
52	C	C	O	C	O	O	C
53	O	C	O	C	O	O	C
54	C	O	O	C	O	O	C
55	O	O	O	C	O	O	C
56	C	C	C	O	O	O	C
57	O	C	C	O	O	O	C
58	C	O	C	O	O	O	C
59	O	O	C	O	O	O	C
60	C	C	O	O	O	O	C
61	O	C	O	O	O	O	C
62	C	O	O	O	O	O	C
63	O	O	O	O	O	O	C
64	C	C	C	C	C	C	O
65	O	C	C	C	C	C	O
66	C	O	C	C	C	C	O
67	O	O	C	C	C	C	O
68	C	C	O	C	C	C	O
69	O	C	O	C	C	C	O
70	C	O	O	C	C	C	O
71	O	O	O	C	C	C	O
72	C	C	C	O	C	C	O
73	O	C	C	O	C	C	O
74	C	O	C	O	C	C	O
75	O	O	C	O	C	C	O
76	C	C	O	O	C	C	O
77	O	C	O	O	C	C	O
78	C	O	O	O	C	C	O
79	O	O	O	O	C	C	O
80	C	C	C	C	O	C	O
81	O	C	C	C	O	C	O
82	C	O	C	C	O	C	O
83	O	O	C	C	O	C	O
84	C	C	O	C	O	C	O
85	O	C	O	C	O	C	O
86	C	O	O	C	O	C	O
87	O	O	O	C	O	C	O
88	CO	C	C	O	O	C	O
89	CO	C	C	O	O	C	O
90	CO	O	C	O	O	C	O
91	CO	O	C	O	O	C	O
92	C	C	O	O	O	C	O
93	O	C	O	O	O	C	O
94	C	O	O	O	O	C	O
95	O	O	O	O	O	C	O
96	C	C	C	C	C	O	O
97	O	C	C	C	C	O	O
98	C	O	C	C	C	O	O
99	O	O	C	C	C	O	O



Fibre ID	Jmp 0	Jmp 1	Jmp 2	Jmp 3	Jmp 4	Jmp 5	Jmp 6
100	C	C	O	C	C	O	O
101	O	C	O	C	C	O	O
102	C	O	O	C	C	O	O
103	O	O	O	C	C	O	O
104	C	C	C	O	C	O	O
105	O	C	C	O	C	O	O
106	C	O	C	O	C	O	O
107	O	O	C	O	C	O	O
108	C	C	O	O	C	O	O
109	O	C	O	O	C	O	O
110	C	O	O	O	C	O	O
111	O	O	O	O	C	O	O
112	C	C	C	C	O	O	O
113	O	C	C	C	O	O	O
114	C	O	C	C	O	O	O
115	O	O	C	C	O	O	O
116	C	C	O	C	O	O	O
117	O	C	O	C	O	O	O
118	C	O	O	C	O	O	O
119	O	O	O	C	O	O	O
120	C	C	C	O	O	O	O
121	O	C	C	O	O	O	O
122	C	O	C	O	O	O	O
123	O	O	C	O	O	O	O
124	C	C	O	O	O	O	O
125	O	C	O	O	O	O	O
126	C	O	O	O	O	O	O
127	O	O	O	O	O	O	O

**Legend:** O = Open (no jumper) C = Closed (jumper on)

### ***Option Settings***

Additional drive option jumpers for remote and delayed start are located on the unit I/O board. They must be set at the factory.

#### **Remote Start**

This feature is disabled by default and can be enabled for OEM use.

#### **Delayed Start**

This feature is disabled by default and can be enabled for OEM use.

### ***Fibre Channel Speed Selection (W5)***

This jumper will need to be set to the speed of the Fibre Channel. Set this jumper for either 1Gb/s or 2Gb/s operation. The Blower assembly must be removed to access jumper W5. Refer to [Chapter 5](#) for blower removal procedure.



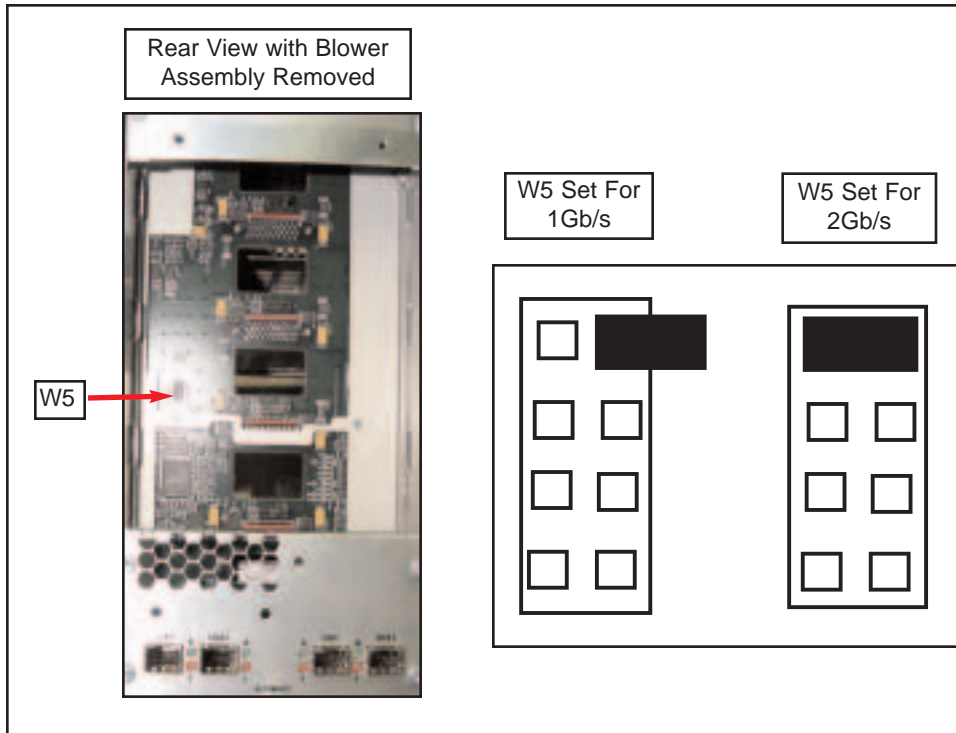

## Rear I/O Connections

The rear of the unit and the I/O connections are described below.

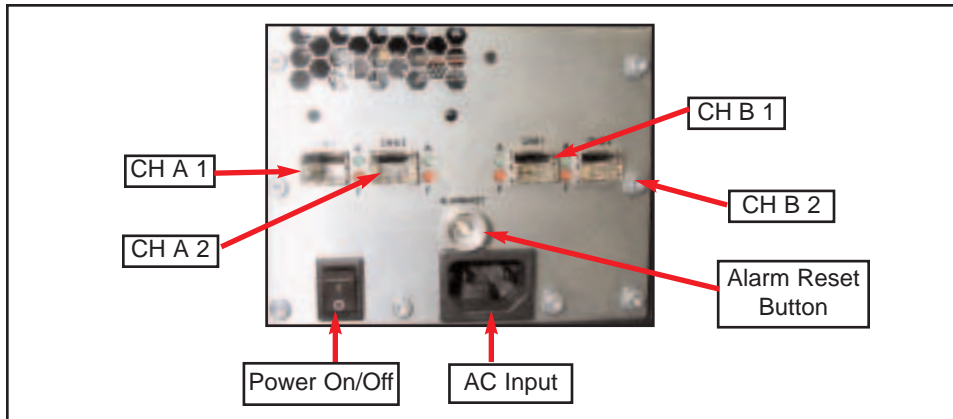

### CH-A 1

Loop A connection 1. This is a SFP fibre channel connector used to connect to a host system or to an expansion chassis for Loop A.

### CH-A 2

Loop A connection 2. This is a SFP fibre channel connector used to connect to a host system or to an expansion chassis for Loop A.

**CH-B 1**

Loop B connection 1. This is a SFP fibre channel connector used to connect to a host system or to an expansion chassis for Loop B.

**CH-B 2**

Loop B connection 2. This is a SFP fibre channel connector used to connect to a host system or to an expansion chassis for Loop B.

**System Fault Audible Alert**

A system fault includes over temperature, power fault, or blower fault. The buzzer will sound off with a sequence of beeps to indicate the fault that has occurred.

- 2 beeps = Temperature Fault
- 3 beeps = Blower Fault;
- 5 beeps = Power Supply Fault.

**Alarm Reset**

This button will turn off the audible alert. Pressing this button will not reset power to the unit, it will only silence the alarm.

## 5. Blower Operation

This chapter covers all operations of the blower for 6-bay units. Refer to Chapter 1 for blower specifications. The blower is easily removable. Failure to replace a non-working blower within a reasonable period of time may expose drives to extreme heat that could cause loss of data.

**WARNING:** *Blowers are a system critical component. Non-operating blowers should be replaced as soon as possible to avoid data loss or device failure.*

**WARNUNG:** *Gebläse sind für die Funktion wichtige Komponenten. Nicht funktionierende Gebläse sollten so schnell wie möglich ersetzt werden, um Datenverluste oder Fehlfunktionen zu vermeiden.*

The blower is located on the back of the unit. If there is a blower fault, both of the device canister status LEDs will blink 'Red' and an audible alert will sound. Pressing the Alarm Reset button located on the back of the unit will turn off the audible alert.

**WARNING:** *Because the blower continues to spin for a short while, the unit should be turned off at least 10 seconds before replacing the fan to prevent injury.*

**WARNUNG:** *Um Verletzungen zu vermeiden, sollte das Gerät wenigstens 10 Sekunden vor Entnahme der Gebläse ausgeschaltet werden, da die Flügelräder der Gebläse nachlaufen.*

### Blower Removal/Insertion

The blower is designed to be easily installed and removed.

1. Unfasten the blower thumbscrew by turning counterclockwise. A Philips head screwdriver can be used if the thumbscrew is too tight to turn by hand.

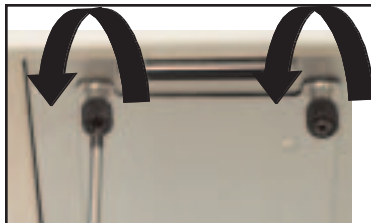

2. Remove the blower canister by pulling out on the thumbscrews and lifting it out of the bottom two slots.

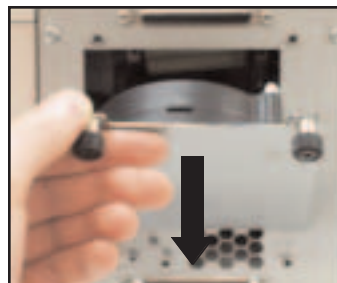

- Unplug the blower from the backplane. The connector is keyed so that it can be reinstalled correctly and has also been placed through a holder on the fan bracket to keep it out of the way during fan installation and removal.



Reverse the steps to reinstall the blower.

The following figure shows the blower intake access hole. Contact with the access hole must be avoided while the blower is running to prevent injury.



**WARNING:** Avoid direct contact with the blower intake access hole while the blower is running. The blower operates at high speeds and can cause injury.

## Blower Replacement

If the blower has stopped running or the front device canister status LEDs are all blinking 'Red', the blower may need to be replaced.

Before replacing, the cable connection should be checked to ensure that the connector is firmly seated and that there is nothing blocking the blower intake blades that could cause interference. If you believe a blower is in a nonfunctional state, please contact the place of purchase for repair or replacement.

The JMR part numbers for a replacement blower is shown in the table below. Replacement parts include the canister with the fan.

Model	JMR Part Number
6-bay	FAD-00014

**WARNING:** Blowers are a system critical component. Non-operating blowers should be replaced as soon as possible to avoid data loss or device failure.

**WARNUNG:** Gebläse sind für die Funktion wichtige Komponenten. Nicht funktionierende Gebläse sollten so schnell wie möglich ersetzt werden, um Datenverluste oder Fehlfunktionen zu vermeiden.

# 6. Power Supply Operation

This chapter covers the operations of the power supply for 6-bay units. For operation, the AC cord (included) must be connected to the AC Inlet at the back of the unit, and the On/Off switch must be switched ON. The Status LED on the power supply will light to indicate the power supply is functioning properly. If the power supply experiences a problem and cannot operate within its normal specifications, the Status LED will light 'Red' and an audible alert will sound. Pressing the Alarm Reset button located on the back of the unit will turn off the audible alert.

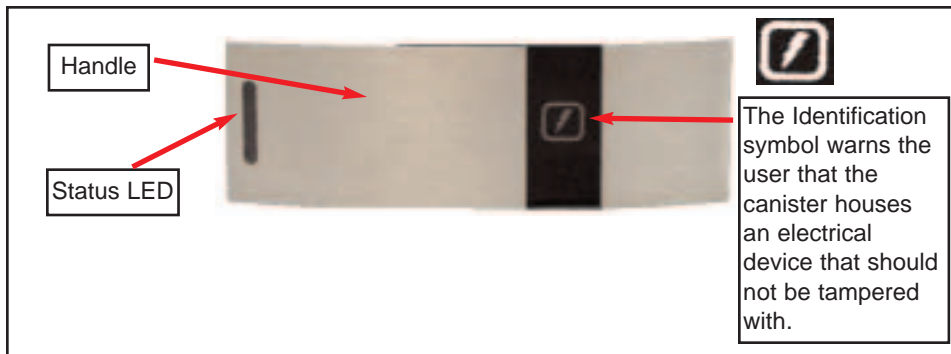

## Power Supply Removal/Insertion

Follow the following steps to remove a power supply in a 6-bay unit.

1. Unlock the unit (see [Chapter 3](#) for Device Installation instructions) & open the handle by pulling out. This action will disconnect the supply canister from the unit.



2. Grab the handle and pull straight out.



3. Carefully remove the supply from the unit. It is ok to grab the sides of the supply to fully remove it.

Reverse the steps to reinstall the power supply.

## Power Supply Replacement

If the Power supply Status LED indicator is 'Red', the power supply may need to be replaced. The unit should be reset (turned on & off), and the power supply should be removed and then reinstalled. The AC cable connection in the back of the unit should be checked to ensure that the plug is firmly seated in the power supply. If the Status LED indicator is still 'Red', then the power supply should be replaced.

If the power supply fan is not functioning but the power supply still works, the power supply should be replaced as soon as possible. Leaving the power supply running without the fan could cause the power supply to overheat and shutdown at any time and may cause damage to the supply and other installed devices.

If you believe a power supply is in a nonfunctional state, please contact the place of purchase for repair or replacement.

The JMR part number for a replacement power supply is shown in the following table. Replacement parts include the canister with the power supply.

<b>Model</b>	<b>JMR Part Number</b>	<b>Color</b>
6-bay	KDSH-085-01	Silver
6-bay	KDSH-085-02	Black

## 7. Product Support

For current information on this product, including updates to the manual and technical support related issues, please contact the sales support section of our web page at [www.jmr.com](http://www.jmr.com), or you can contact our Technical Support division directly at the address below.

### US Corporate Headquarters

JMR Electronics, Inc.

ATTN: Technical Support Division

20400 Plummer St.

Chatsworth, CA 91311

Customer Support: (818) 739-1140

E-mail: [techsupport@jmr.com](mailto:techsupport@jmr.com)

Office Hours: Monday-Friday 8:00 A.M. to 5:00 P.M., Pacific Standard Time

Internet: <http://www.jmr.com>

### Manual Changes

Revision A - Initial Release



# Appendix A. Drive and Controller Manufacturers

## Drive Manufacturers

Fujitsu

Internet Address: [www.fcpa.com](http://www.fcpa.com)

Hitachi

Internet Address: [www.hitachi.com](http://www.hitachi.com)

IBM (International Business Machines Corporation)

Internet Address: [www.ibm.com](http://www.ibm.com)

Maxtor

Internet Address: [www.maxtor.com](http://www.maxtor.com)

Seagate Technology

Internet Address: [www.seagate.com](http://www.seagate.com)

## RAID Controller Manufacturers

Adaptec, Inc.

Internet Address: [www.adaptec.com](http://www.adaptec.com)

Chaparral Network Storage

Internet Address: [www.chaparralnet.com](http://www.chaparralnet.com)

Digi-Data Corporation

Internet Address: [www.digidata.com](http://www.digidata.com)

Infortrend Corporation

Internet Address: [www.infortrend.com](http://www.infortrend.com)

Intel ICP VORTEX (Intelligent Computer Peripherals)

Internet Address: [www.icp-vortex.com](http://www.icp-vortex.com)

Mylex Corporation

Internet Address: [www.mylex.com](http://www.mylex.com)

Silicon Image, CMD Storage Systems

Internet Address: [www.cmd.com](http://www.cmd.com)





## Host Bus Adapter Manufacturers

Adaptec, Inc.

Internet Address: [www.adaptec.com](http://www.adaptec.com)

Antares Microsystems

Internet Address: [www.atares.com](http://www.atares.com)

Emulex Corporation

Internet Address: [www.emulex.com](http://www.emulex.com)

JNI Corporation

Internet Address: [www.jni.com](http://www.jni.com)

QLogic Corp.

Internet Address: [www.qlogic.com](http://www.qlogic.com)

